

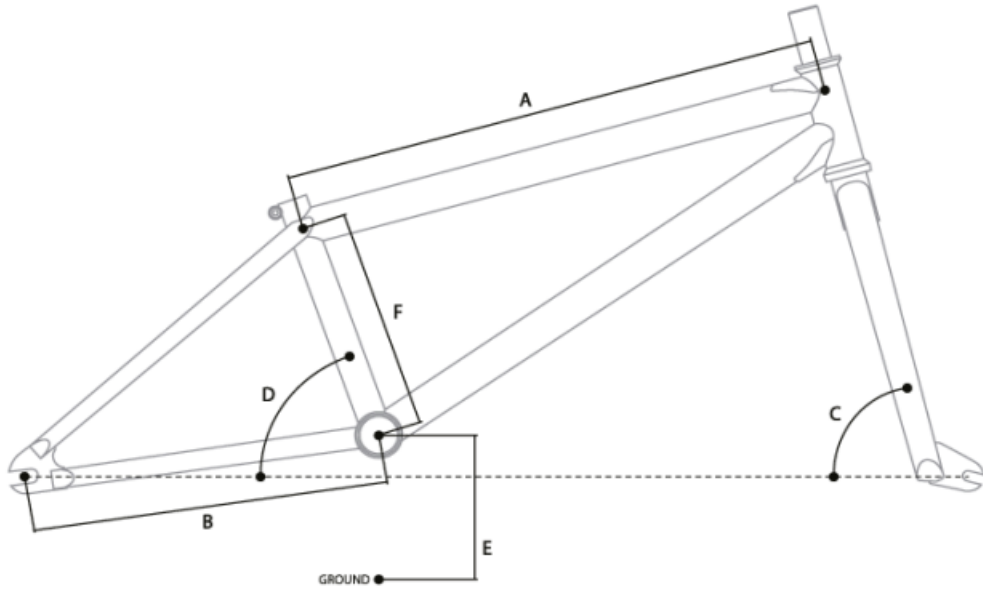

**Base price:** \$550  
**Powder coat:** + \$50 (single coats) + \$75 (multi coat/fades)  
 Powder coat colors available at [www.prismaticpowders.com](http://www.prismaticpowders.com)



**A) Top tube length:** \_\_\_\_\_ inches  
**B) Chain stay length (slammed):** \_\_\_\_\_ inches  
**C) Head tube angle:** \_\_\_\_\_ degrees  
**D) Seat tube angle:** \_\_\_\_\_ degrees  
**E) Bottom bracket height:** \_\_\_\_\_ inches  
**F) seat tube length (stand over):** \_\_\_\_\_ inches

**Head tube length:**  
 (5"/127mm) (4.72"/120mm) (4.6"/117mm)  
**Top tube diameter:**  
 (1.25"/31.8mm) (1.375"/34.9mm)  
**Top tube style:**  
 (double butted) (straight gauge)  
**Down tube diameter:**  
 (1.375"/34.9mm) (1.5"/38.1mm)  
**Down tube style:**  
 (double butted) (straight gauge)

**Bottom bracket size:**  
 (73mm MID) (68mm MID) (73mm EURO) (68mm EURO)

**Head tube gussets:**  
 (top and down tube) (down tube only) (no gussets)

**Seat post clamp:**  
 (integrated seat post clamp) (non-integrated seat post clamp)

**Brake mounts:**  
 (none) (welded U-brake mounts + \$25)  
 (removable 990 mounts + \$50)  
 (120mm disk brake mount + \$50)  
 (120mm disk brake mount with rotor guard + \$75)

**Cable routing chain stay mounted U-brakes:**  
 (routed around seat tube) (routed through seat tube + \$25)

**Chainring size:** \_\_\_\_\_ **Tire width:** \_\_\_\_\_

**Seat stay style:**  
 (3/4" diameter) (3/4" to 5/8" tapered)

**Chain stay style:**  
 (3/4" diameter) (3/4" to 5/8" tapered)

**Bridge diameter:**  
 (5/8" straight tube) (3/4" straight tube)

**Dropout size:**  
 (14mm) (3/8")

**Chain tensioners + \$50:**  
 (yes) (no)

**Chain stay grind protectors + \$100:**  
 (yes) (no)

**Top tube/seat stay junction:**  
 (standard top tube/seat stay junction)  
 (pierced top tube seat stay junction + \$75)